

the **e** senses

e-Sense **Active**

FAGERHULT

Content

e-Sense Active – functions and benefits	3
IR Programming unit, IR Remote control	4
Programming with IR programming unit	5
Basic functions	5
Manual Settings	6
Settings for Daylight Harvesting	6
Offset Settings	7
Bright Out Settings	7
Presence detection mode and time setting	8–9
Power ON setting	9
Select communication	9
Function with presence detection	10
Default settings	10
Wiring examples	11–12
Sensor function and limitations	13
Technical specification	14

e-Sense Active

e-Sense Active system lighting control consists of a small compact sensor and a control unit. Both are designed for assembly in a luminaire. e-Sense Active is simple system for "plug and play" installations and lighting solutions, mostly in offices. A pendant luminaire, or a small group of luminaires can be controlled. Active is using a "master –slave" control that is easy to install, program and use.

Functions and benefits

- e-Sense Active is a control system based on DALI communication.
- e-Sense Active is a "plug and play" system that don't require any special knowledge in lighting control.
- e-Sense Active consists of three small sensors in a common housing that is connected to a control unit.
- The sensor for measuring light is very sensitive to visual light, like a human eye. This function is used as Daylight Harvesting and has a potential to saves a lot of energy.
- The PIR sensor is very sensitive to human movement. In combination with programmable delay time will optimise the function in an office.
- Manual control can be done with a IR-remote control (86415), a impulse push button or and pull cord on the luminaire.
- Additional settings can be done for behavior after return of power etc. with a IR-remote control for programming (86414).

e-Sense Active

- Compact dimensions for luminaire installation
- For up to 10 DSI or DALI devices distributed on 2 channels
- 2 DALI/DSI output channels with adjustable negative offset from channel 2 to channel 1
- Ambient light sensor with motion detector
- Max. installation height 5 m
- Switch input for on/off switching and dimming
- Can be remote controlled
- Individual adjustment of the parameters with IR programming unit (86414).

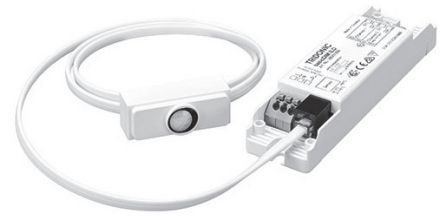

IR programming unit 86414

- Optional infra-red programming unit for e-Sense Active
- Programmable functions such as light level, time delay, P.I.R., bright-out, power up

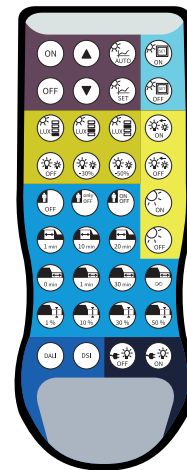

IR remote control 86415

- Switching on and off (On/Off button)
- Dimming (Up/Down button)
- Activation of Daylight Harvesting control
- Setting the value for Daylight Harvesting control point (SET button)



Programming with IR programming unit 86414

This manual describes how to program settings for the different functions in the e-Sense Active system. A default setting is done that easy ca be changed with the remote programmer. Follow the manual to program the different parameters. No programmed function is lost after a power loss.

Default settings

Light level power up	70 %
Delay Time	10 min.
Standby Time	1 min.
Standby light level	10 %
PIR sensor	Activated
Daylight Harvesting	Activated
Power up	ON
Manual setting of Daylight Harvesting	Deactivated
Daylight Harvesting setting	500 lux
DALI or DSI	DALI
Offset Mode at 100 %	Converging
Offset %	-30 %

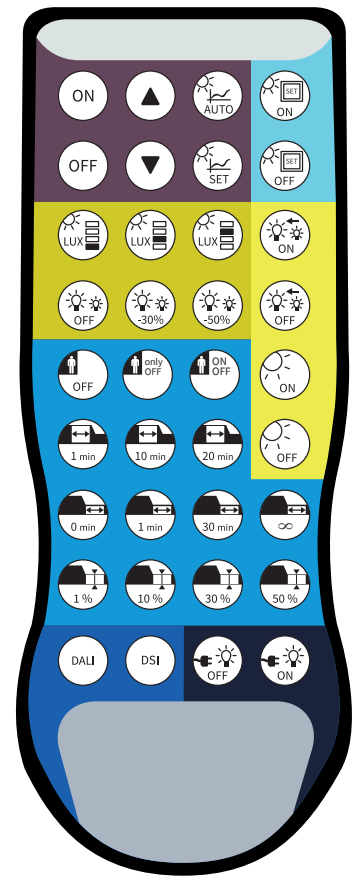

Basic functions

These functions are also available on IR remote control 86415.



Switch light ON.



Change to Daylight Harvesting Mode.



Switch light OFF.



Save current light level as target value for Daylight Harvesting function.



Increase light level.



Decrease light level.

Manual Settings

Manual setting of light level during daylight harvesting with an impulse switch or a pull cord dim function on the luminaire.



Enable saving current level as Daylight Harvesting target value.
Double push on the switch (or pull cord) will store the new level.



Disabling the store function.

Settings for Daylight Harvesting

A setting will increase, or decrease the artificial light level according to how much ambient light is affecting the room.



Light level low, approx. 150 lux.



Light level medium, approx. 300 lux.



Light level high, approx. 500 lux.
Standard for office desk light in many countries.

NOTE!

The above lux values refers to the approximate illuminance measured on the table surface under the luminaire without the influence of other light such as sunlight or light from other fixtures. If the desired illuminance is not reached, it should be set manually with the "SET" button.

Offset Settings

The offset function can be used to define the difference between light level for the two channels. Channel 1 is affected by the offset function. Channel 2 keeps the base light level.



Offset value 0%.
The two channels will dim simultaneously between min. level and max.



Offset value -30%.
The two channels will dim with a difference of -30%. This means that channel 1 will always be 30% higher than channel 2. Light at full level is dependent of setting Offset Mode.



Offset value -50%.
The two channels will dim with a difference of -50%. This means that channel 1 will always be 50% higher than channel 2. Light at full level is dependent of setting Offset Mode.



Offset Mode Converging.
The two channels will dim at the difference set in Offset value. But when increasing light (controlling up), both channels will reach full level at the same time.



Offset Mode fixed.
The two channels will dim at the difference set in Offset value. But when increasing light, channel 2 will end at a lower value according to Offset value setting.

Bright Out Settings

Bright Out can be used to switch light off if the Daylight Harvesting level is exceeded by 150%. If ambient light decreases under 100% of set value, light turns on again.



Bright Out ON.
Will switch light OFF if ambient light is over 150%. And back to ON if reading value is under 100%.



Bright Out OFF.
Light remains ON as long as presence is detected.

Presence detection mode and time setting

Settings of PIR functions. PIR stands for Passive Infra Red. The sensor detects body heat.



PIR inactive.
The PIR sensor is totally disabled. No time functions at all.



PIR Manual mode.
Light do not turn on automatically. A manual switch (or pull cord) must be used. An IR-remote control 86415 can also be used.



PIR Auto mode.
Light turns ON and OFF automatically. Delay time is set to 10+10 minutes.



Delay Time 1 min.
After last presence detection and with a delay of 1min. light dims to Standby Dimming Level or OFF.



Delay Time 10 min.
After last presence detection and with a delay of 10min. light dims to Standby Dimming Level or OFF.



Delay Time 20 min.
After last presence detection and with a delay of 20min. light dims to Standby Dimming Level or OFF.



Delay Time 0 min.
After last presence detection and with a delay of set value from above, light goes to OFF.



Standby Time 1 min.
Light will remain on Dimming level for 1min.



Standby Time 30 min.
Light will remain on Dimming level for 30min.



Standby Time "Infinite".
Light will remain on Dimming level forever. Or if mains is powered OFF.

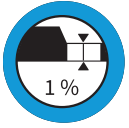

Standby dimming Level 1 %.
Light will dim to 1 % after Delay time elapsed.

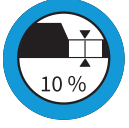

Standby dimming Level 10 %.
Light will dim to 10 % after Delay time elapsed.

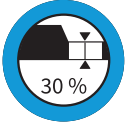

Standby dimming Level 30 %.
Light will dim to 30 % after Delay time elapsed.



Standby dimming Level 50 %.
Light will dim to 50 % after Delay time elapsed.

Power ON setting



ON.
Light goes to ON after mains returns.



OFF.
Light remains OFF after mains returns.

Select communication



DALI.
DALI communication is active.



DSI.
DSI communication is active. Never use.

Presence detection behavior

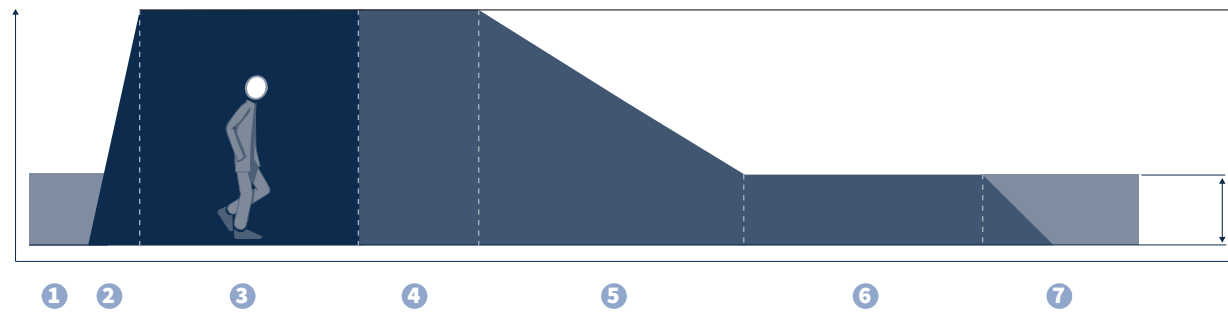

- 1 Lights off or at a low level
- 2 Light controls automatically up to daylight harvestil level, or after manual on
- 3 Presence
- 4 Delay time after last presence
- 5 Diming to stand by level
- 6 Stand by dimming level
- 7 Off, or remaining at stand by dimming level, depending on programming

Default settings

Light level power up	70 %
Delay Time	10 min.
Standby Time	10 min.
Standby light level	20 %
PIR sensor	Activated
Daylight Harvesting	Activated
Power up	ON
Manual setting of Daylight Harvesting	Deactivated
Daylight Harvesting setting	Light level high, approx. 500 lux
DALI or DSI	DALI
Offset Mode at 100 %	Converging
Offset %	-30 %
Bright Out	Deactivated

Wiring example

e-Sense Active Single Luminaire with pull cord control (suffix -538)

A pendant solution with presence detection, daylight harvesting, and manual control via the pull cord. Additional luminaires can be connected.

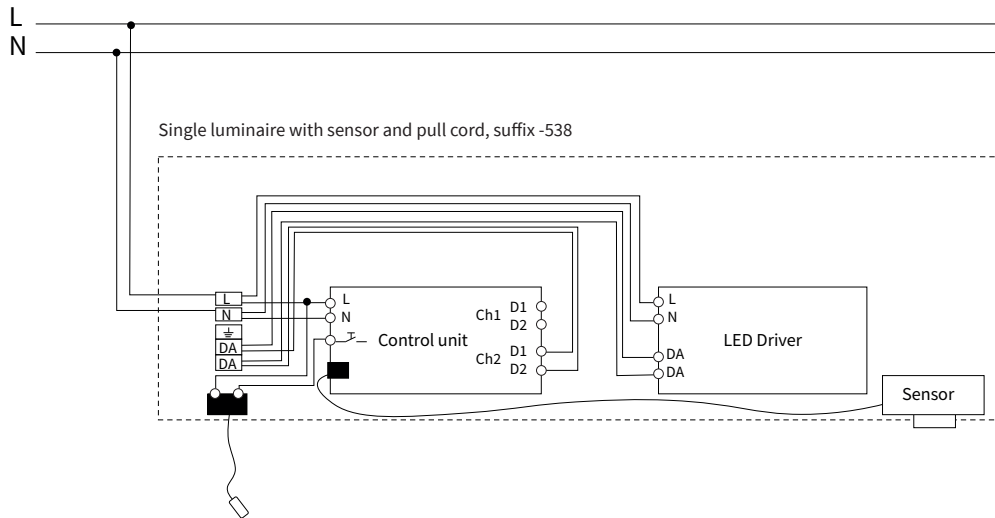

e-Sense Active Single Luminaire with pull cord control and additional luminaire (suffix -538)

A pendant solution with presence detection, daylight harvesting, and manual control via the pull cord. Additional luminaires connected.

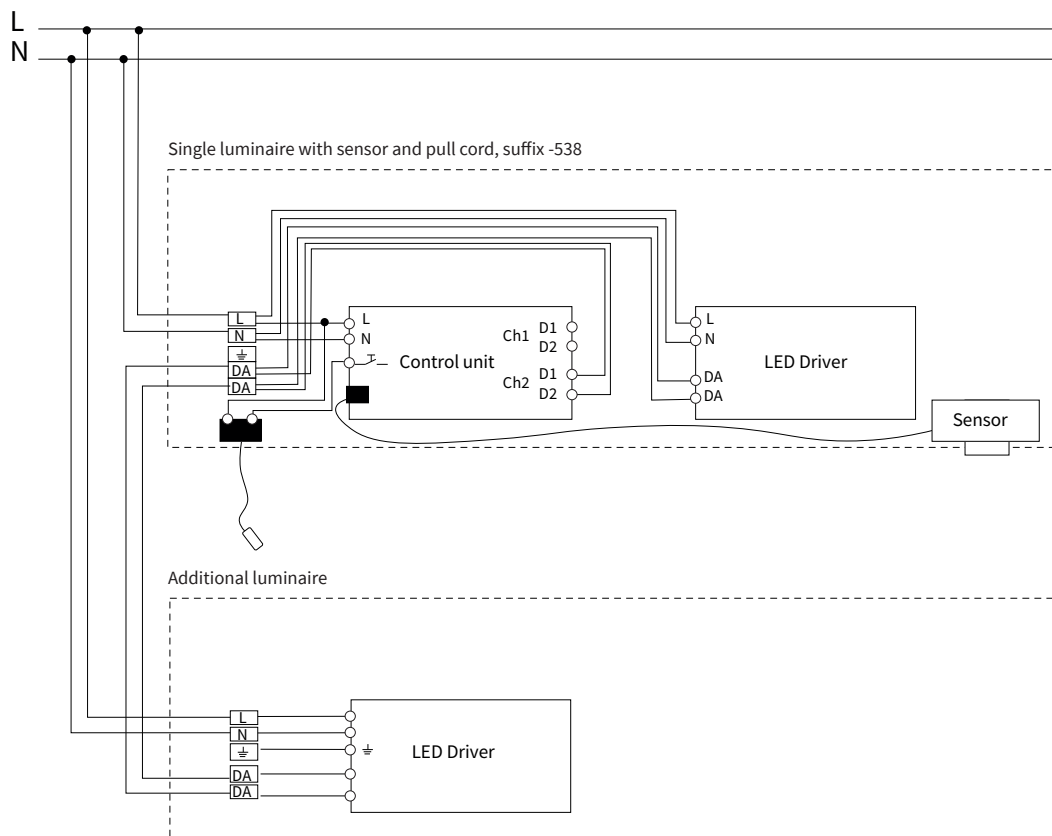

Wiring example

e-Sense Active Single/Master Luminaire with push button control and additional luminaires (suffix -537)

A pendant solution with presence detection, daylight harvesting, and manual control via the pull cord. Additional luminaires connected, one with offset dimming.

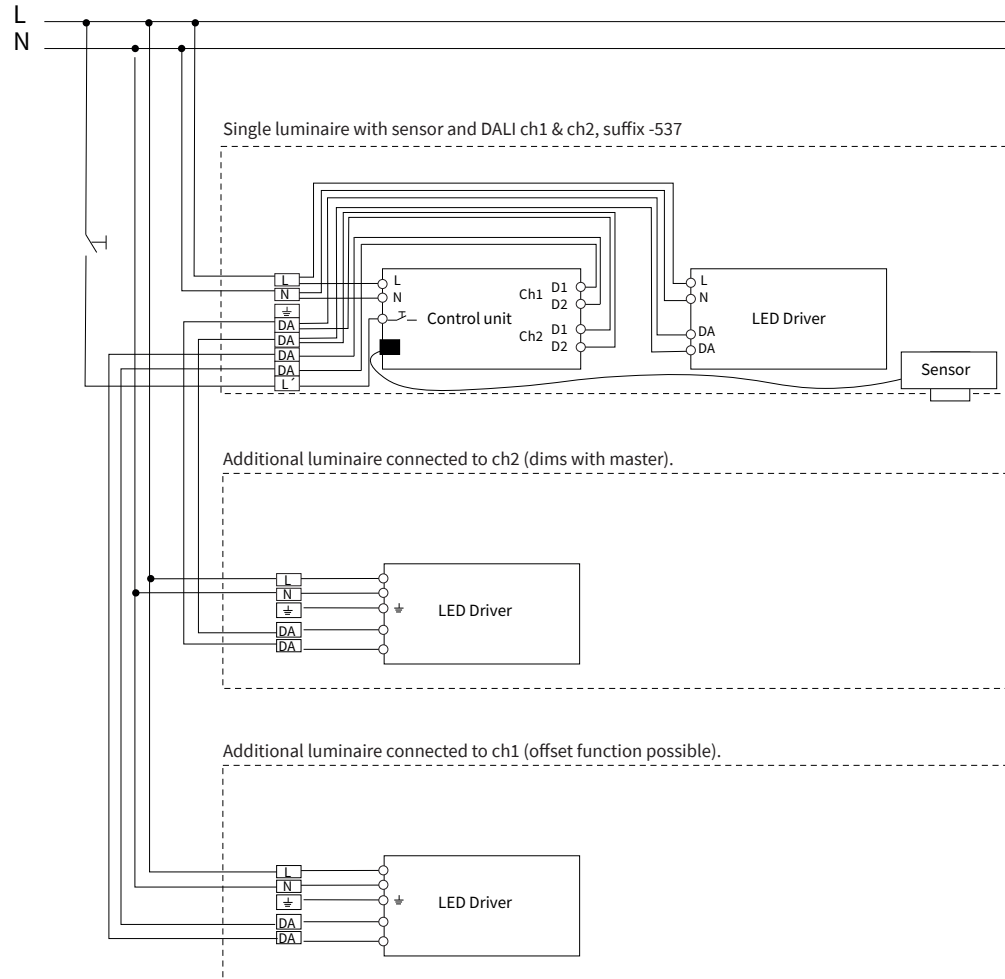

e-Sense Active Single Luminaire (suffix -539)

A pendant solution with presence detection and daylight harvesting.

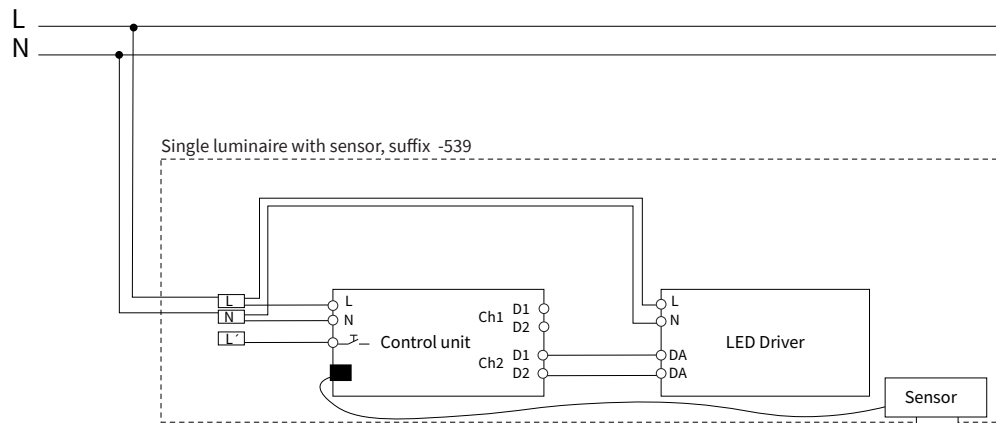

Sensor function and limitations

e-Sense Active sensor detects presence and reads light reflected into the sensor.

PIR detects movement and will start to time out the delay time first when no more presence is detected. Any more movement before time out, will reset the delay time to start. Lux level, used as daylight harvesting for saving energy, can also be used to create an even light level through out a room with the offset function.

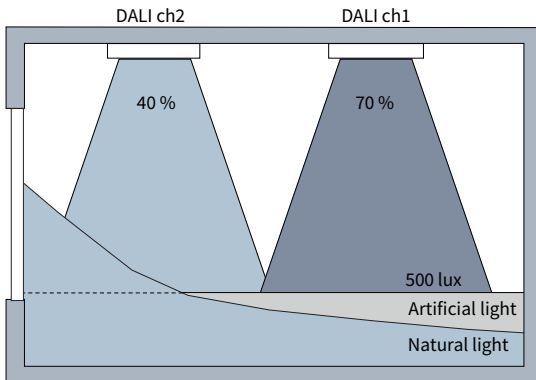

Example for a room with -30 % offset for channel 1. Channel 1 is brighter and light is further away from the window than channel 2. This will create an even light level in the whole area.

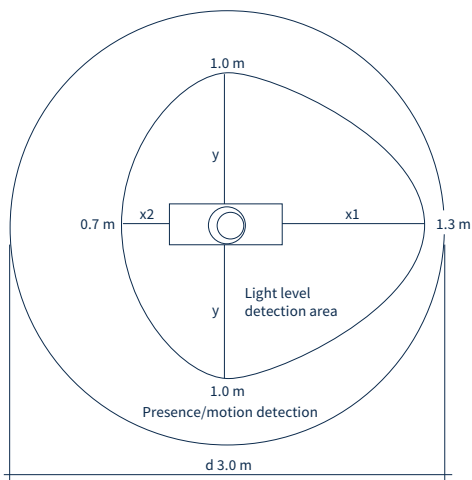

Example for light and motion detection area at height 1.7 m.

h^*	x_1	x_2	x_3	x_4
1.7 m	1.3 m	0.7 m	1.0 m	3.0 m
2.0 m	1.6 m	0.8 m	1.2 m	3.6 m
2.3 m	1.8 m	0.9 m	1.3 m	4.1 m
2.5 m	2.0 m	1.0 m	1.4 m	4.5 m
2.7 m	2.1 m	1.1 m	1.6 m	4.9 m
3.0 m	2.3 m	1.2 m	1.7 m	5.4 m
3.5 m	2.7 m	1.4 m	2.0 m	6.3 m
4.0 m	3.1 m	1.6 m	2.3 m	7.2 m

The recommended maximum room height for office applications is 3 m and for corridor applications for example 4 m. (The sensor detects well also at 5 m height).

Up to 2 mounting height presence is detected and over 2 m motion is detected.

Technical specification

Rated supply voltage	220 – 240 V
Mains frequency	50 / 60 Hz
Power	2 W
Stand-by power	0.5 W
Momentary-action switch input for dimming single	
Digital control line	DSI/DALI 2
Control output (devices)	10
Max. output cable length at 1.5 mm ²	100 m
Operating temperature	0 ... +60 °C
Storage temperature	-25 ... +70 °C
Type of protection	IP20
Max. casing temperature tc	75 °C

e-Sense **Active**

Fagerhult develops, manufactures and markets professional lighting systems for public environments. Our operations are run with a constant focus on design, function, flexibility and energy saving solutions.

Fagerhult is part of the Fagerhult Group, one of Europe's leading lighting groups with operations in more than 15 different countries. AB Fagerhult is listed on the NASDAQ OMX Nordic Exchange in Stockholm.

HEAD OFFICE SWEDEN
Fagerhults Belysning AB
SE-566 80 Habo, Sweden
Tel +46 36 10 85 00
Fax +46 36 10 86 99
www.fagerhult.se